

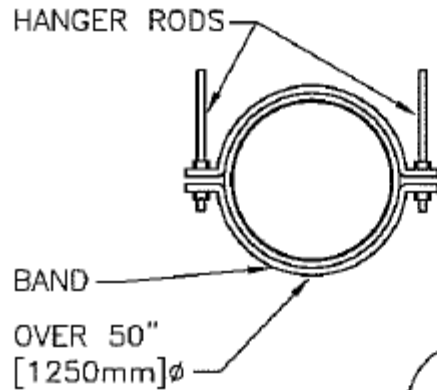

KOLSTEN INDUSTRIAL

Kolsten Industrial
210 N. Pasedena St.
Gilbert, AZ 85233

Phone: (480) 339-1900
FAX: (480) 339-1901
www.kolstenindustrial.com

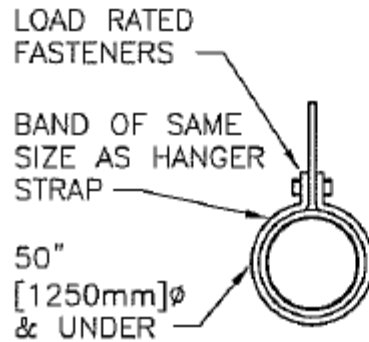

HANGER STRAPS OR RODS			
MAX. DUCT ϕ IN. [mm]	QUANTITY/SIZE IN. [mm]	MAX. LOAD LBS. [kg]	MAX. SPACING IN. [mm]
26 [650]	ONE 1 [25] x 22 GA STRAP	260 [119]	144 [3600]
36 [900]	ONE 1 [25] x 18 GA STRAP	420 [190]	144 [3600]
50 [1250]	ONE 1 [25] x 16 GA STRAP	700 [317]	144 [3600]
60 [1500]	TWO 3/8 [10] ϕ . RODS	1320 [598]	144 [3600]
84 [2100]	TWO 1/2 [13] ϕ RODS	2500 [1133]	144 [3600]

NOTE:
TABULATED DATA FROM SMACNA
ALLOWS FOR DUCT REINFORCING AND
INSULATION, BUT NO EXTERNAL LOAD.

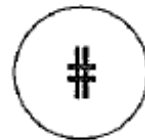

ROUND DUCT HANGERS

NTS

DESIGNER'S NOTE:
DESCRIBE OR DETAIL UPPER ATTACHMENTS APPLICABLE TO PARTICULAR
PROJECTS.